



WORK SMART WORK EFFICIENCY

# Heavy Duty Cash Drawer

## Classic Roller Series **CD-410**

Made of heavy gauge steel, suitable for heavy duty use and prolonged operational life, the ideal choice for reliability and perfect platform for any EPOS terminal also the ideal base for large size ECR.



**CD-410**

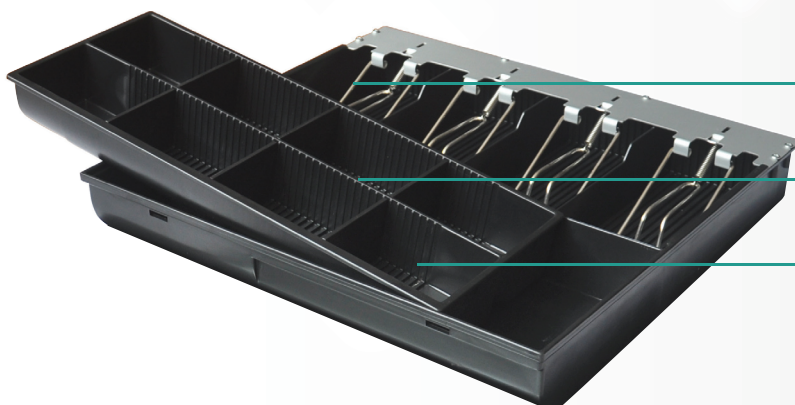

Durable Metal Wire Gripper Bill Holder  
Tested over one million operations

Easy and comfortable operation. Human  
Engineering Design

Removable and adjustable cash tray

# CD-410 Specifications

<b>MODEL NUMBER</b>	<b>CD-410</b>
<b>PHYSICAL</b>	
<b>Dimension</b>	410(W)x420(D)x100(H)mm
<b>Construction</b>	Thick gauge cold rolled steel & SECC
<b>Finish</b>	Textured hybrid powder coat
<b>Color</b>	Black
<b>Roller</b>	Polyurethane for smooth operation
<b>CASH TRAY (INSERT)</b>	
<b>Construction</b>	Shatter-resistant plastic
<b>Currency Layout</b>	4 Bill with Metal, Metal wire grips, 8 Adjustable coin slots
<b>Media Slots</b>	2
<b>OPERATION</b>	
<b>Drawer Lock</b>	3-Position lock / 4-Functions: locked open/closed, manual open, electronically driven
<b>Interface</b>	RJ11 (Option : USB)
<b>Lifecycle</b>	MTBF 1,000,000 times +
<b>Micro Switch</b>	Cash Drawer Status Micro Switch

<b>PACKING DETAILS</b>			
Models	Net Weight(kg)	Gross Weight(kg)	Carton Size(cm)
CD-410	7.8	8.8	47.0 × 48.0 × 17.0

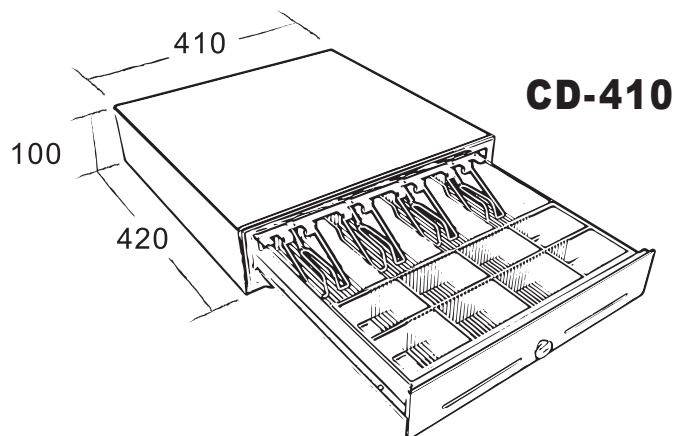

*Specifications are subjected to change without notice.*

